

S7040

2020-UP CORVETTE C8 - CAT BACK
VALVE DELETE W CARBON FIBER TIPS.
TUNING AND/OR VALVE SIMULATORS
MAY BE REQUIRED.

MBRP®

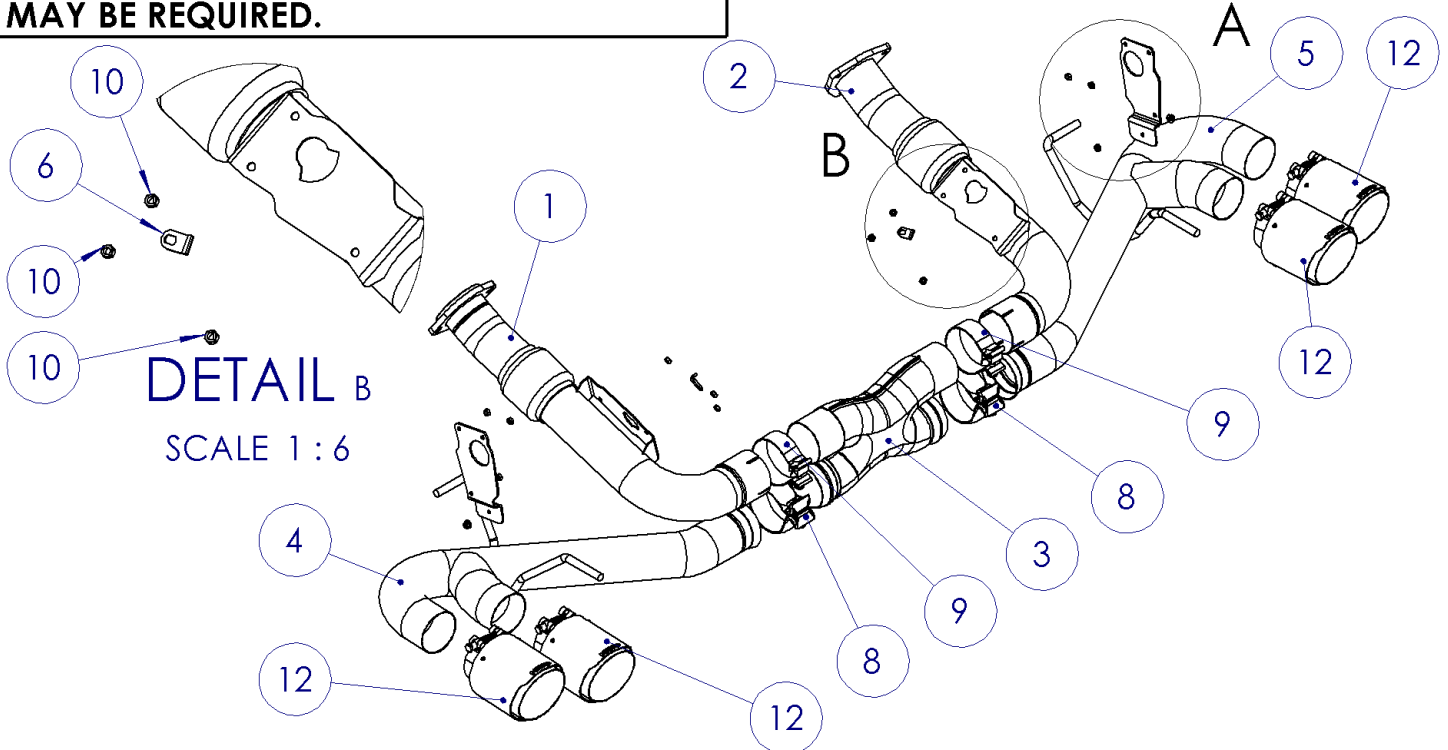

ITEM	DESCRIPTION	QTY.
1	DRIVER-SIDE DOWNPIPE	1
2	PASSENGER-SIDE DOWNPIPE	1
3	X PIPE ASSEMBLY	1
4	DRIVER-SIDE TAILPIPE ASSEMBLY	1
5	PASSENGER-SIDE TAILPIPE ASSEMBLY	1
6	ACTUATOR ARM BRACKET	2
7	NPP ACTUATOR BRACKET	2
8	3.0" SWIVEL CLAMP	2
9	3.0" CLAMP	2
10	M6x1.0 LOCKNUT	12
11	M6x1.0 FLANGE NUT	2
12	TIP	4

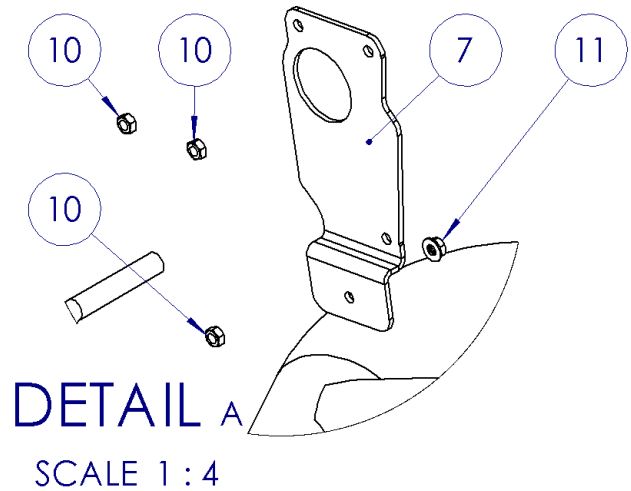

PLEASE READ BEFORE STARTING INSTALLATION

While **MBRP** has made every effort to ensure that all components of this system are of superior quality and properly packaged, it is the installer's responsibility to ensure the following before removal of the factory exhaust:

- that ALL components shown above are present.
- that ALL mating components fit together.
- that there are no damaged components.
- that the system you have purchased is appropriate for your vehicle year, model and configuration.
- that the system will not interfere with any modifications previously installed or planned.
- that you have read and understand these instructions.

If you have any questions or are uncertain about any aspect of the installation of this system to your vehicle please contact your dealer before commencing installation.

MBRP

Removal of Stock System



Figure 1

1. Jack the rear of the vehicle up and remove the rear wheels.
2. Remove the 7mm hex head screws, and 2 plastic push pins along the lower edge of the rear fascia. Remove both rear mud guards followed by the 4 torx head screws located behind them [2 per side] which secure the fender liners to the rear fascia.

Refer to Figures 1 and 2.



Figure 2

3. Remove the torx head screws along the upper edge of the rear fascia.
- Refer to Figure 3.**

4. Pull back the fender liner and remove the two 7mm hex head screws, and M6 flange nut from both sides of the vehicle that secure the rear fascia to the quarter panels.

Refer to Figure 4.

5. Remove the rear fascia from the vehicle by gently lifting it up and rearward. There are 3 electrical connectors located behind the rear fascia that must be disconnected before the fascia can be fully removed. This step will require a minimum of 2 people.



Figure 3

6. Remove the trunk liner to gain access to the engine cover. Remove the torx head screws and remove the engine cover.

Refer to Figure 5.

7. Remove the two M10 flange nuts from the driver side exhaust flange, and three M8 flange nuts from the passenger-side exhaust flange.

8. Disconnect the wiring harness from both AFM exhaust valve actuators located near the exhaust flanges, and both NPP exhaust valve actuators located near the exhaust tips.

9. Remove the OEM exhaust system by first disconnecting it from the front exhaust isolators, then unbolting the rear isolators from the frame. Retain the isolators as they will be reused.



Figure 4

MBRP

Installation of MBRP Performance Exhaust

Tuning and/or Valve Simulators may be required



Figure 5

1. Remove the AFM actuators from the OEM exhaust. Remove the OEM arms from the actuators and install the supplied **Actuator Arm Bracket**.

Refer to Figure 6.



Figure 6

2. Install the AFM actuators onto the **Driver-Side Downpipe** and **Passenger-Side Downpipe** using the OEM bolts and the supplied **M6x1.0 Locknuts**.

Refer to Figure 7.



Figure 7

3. Install the **Passenger-Side Downpipe** using the previously removed M8 Flange nuts. Connect the wiring harness to the AFM actuator. Be sure the OEM gasket is in place.

Refer to Figure 8

4. Install a **3.0" Clamp** onto the outlet of the **Passenger-Side Downpipe** and install the **X Pipe Assembly**.

NOTE: position the clamp with the stud rearward and facing down for easy access when the rear fascia is installed.

Refer to Figure 9.



Figure 8

5. Install a **3.0" Clamp** onto the outlet of the **Driver-Side Downpipe**.

Insert the **X Pipe Assembly** into the outlet of the **Driver-Side Downpipe**. Install the **Driver-Side Downpipe** using the previously removed M10 Flange nuts. Connect the wiring harness to the AFM actuator. Be sure the OEM gasket is in place. Position the **X Pipe Assembly** so the inlets and outlet are aligned vertically. Tighten the clamps enough to secure the **X Pipe Assembly** but still allow for adjustment.

6. Install an OEM rear Isolator and a **3.0" Swivel Clamp** onto the **Passenger-Side Tailpipe Assembly** before installing it onto the vehicle. Ensure the forward hanger is installed into the front isolator. Secure the rear isolator with the previously removed bolts.

Refer to Figure 10.

7. Repeat step 6 for the **Driver-Side Tailpipe Assembly**.

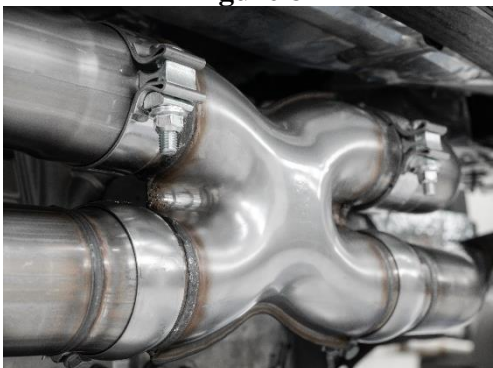

Figure 9

MBRP

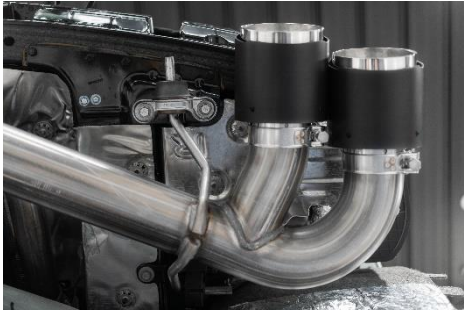

Figure 10

8. Install the NPP actuators onto the supplied **NPP Actuator Brackets** using the OEM bolts and the supplied **M6x1.0 Locknuts**. Refer to **Figure 11**.

9. Remove the wiring harness clips from the M6 studs located above the exhaust outlets and install both **NPP Actuator Brackets**. Secure the brackets with the supplied **M6x1.0 Flange Nuts**. Reconnect the wiring harness to the actuators.

Refer to **Figure 12**.

10. Reinstall the rear fascia in the reverse order as described in the removal process.

11. Install the **Tips** and align to your preference. Complete the final adjustment of the tailpipe assemblies and tighten all clamps.

NOTE: the X Pipe assembly can be swung front to back to adjust the center position of the tips in the rear fascia. The X Pipe Assembly can also be shifted left or right in the Passenger-Side Downpipe expansion joint to adjust the lateral position of the Tips.

Refer to **Figure 13**.

12. Carefully align the system and tips. Align the edge of each band clamp with the edge of the joint it is connecting. Tighten all hardware and clamps, starting at the front and working rearward to secure the system. Check along the full length of the exhaust system to ensure there is adequate clearance for fuel lines, vent lines, brake lines, frame, bodywork, suspension and any wiring, etc. If there is any interference detected, relocate or adjust to provide adequate clearance. Ensure all clamp connections are secure and components are unable to rotate or slide. Band clamps require approximately 45 lb-ft (60 N-m) of torque. Verify clearances, system security and band clamp torque after 30-60 miles (50-100 km) of driving.



Figure 11



Figure 12



Figure 13

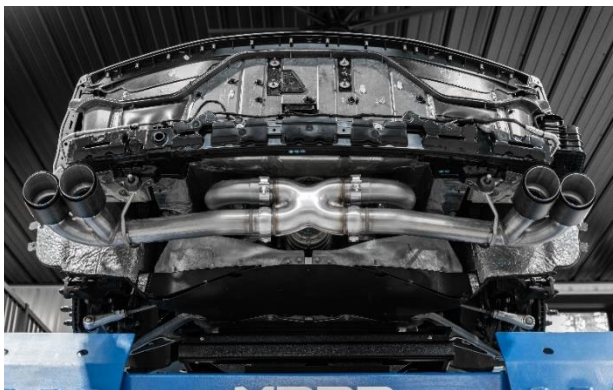

Congratulations! You are ready to begin experiencing the improved power, sound and driving experience of your **MBRP** Performance Exhaust. We know you will enjoy your purchase!